

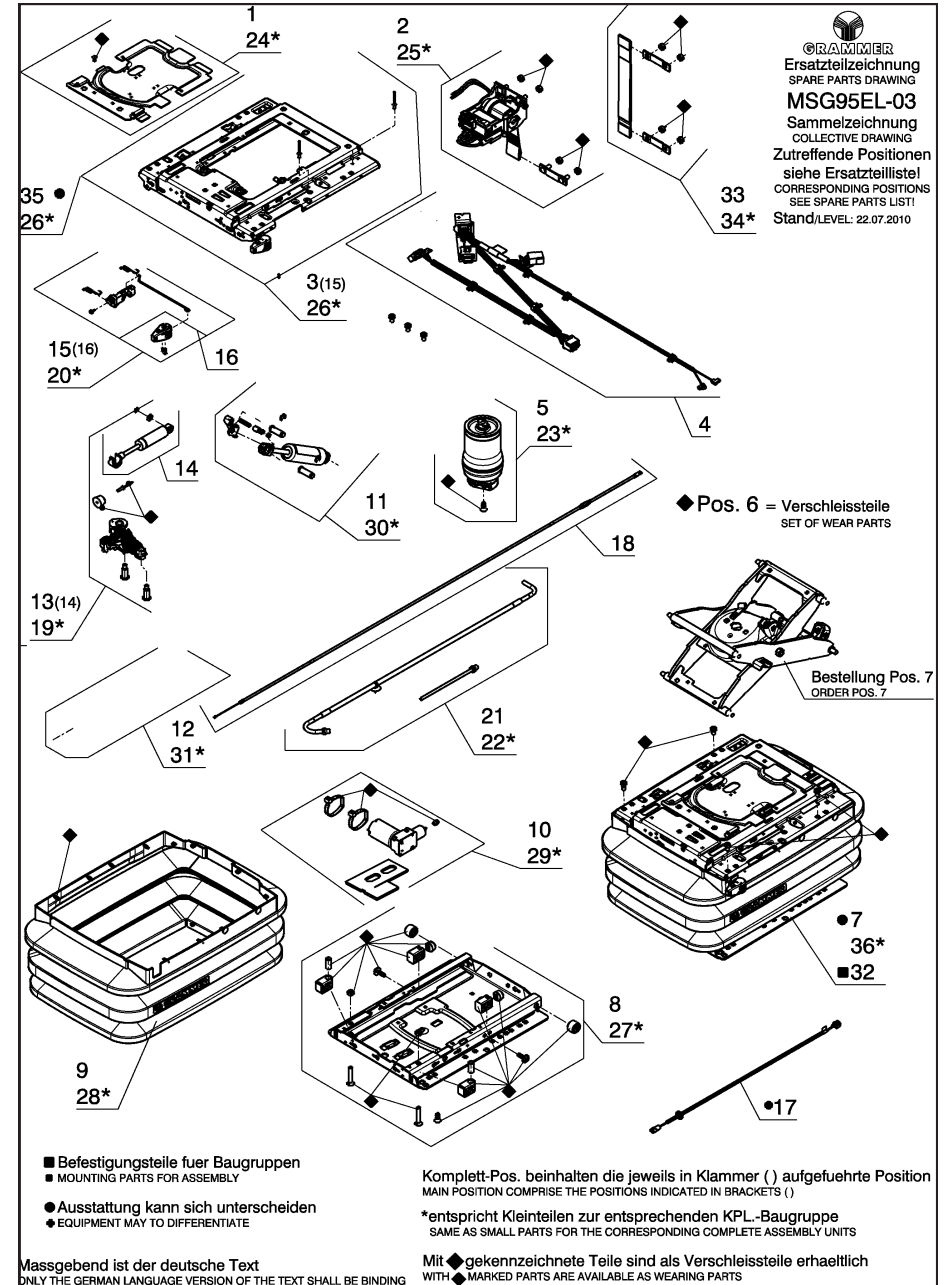

Bitte geben Sie für Ersatzteilbestellungen immer die Sitz-/Sach-Nummer an!

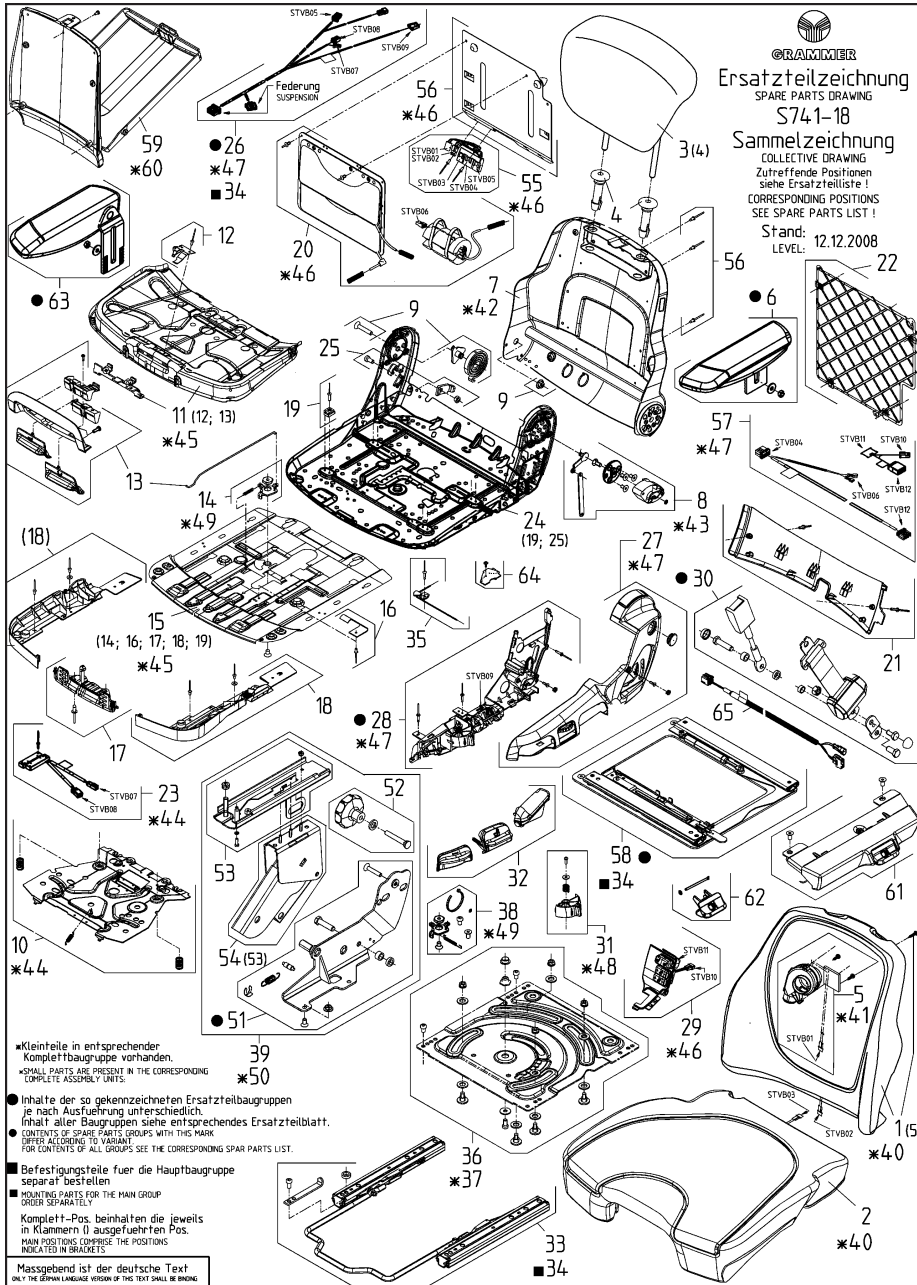

ZEICHNUNG

ZEICHNUNG